

Battery monitor

BMV-700 & BMV-702

quick installation guide

Included

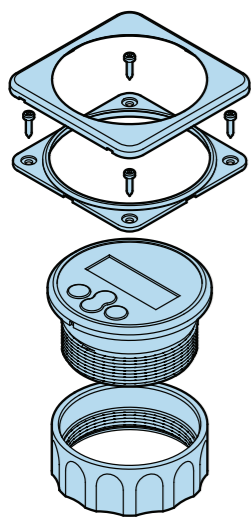

Battery monitor

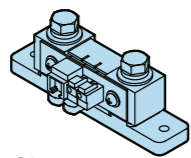

Shunt

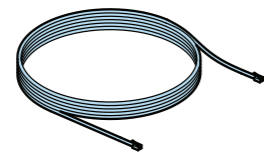

UTP cable

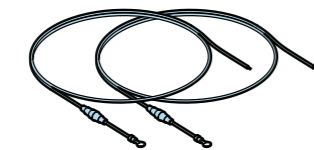

Pos. supply cable (x2)

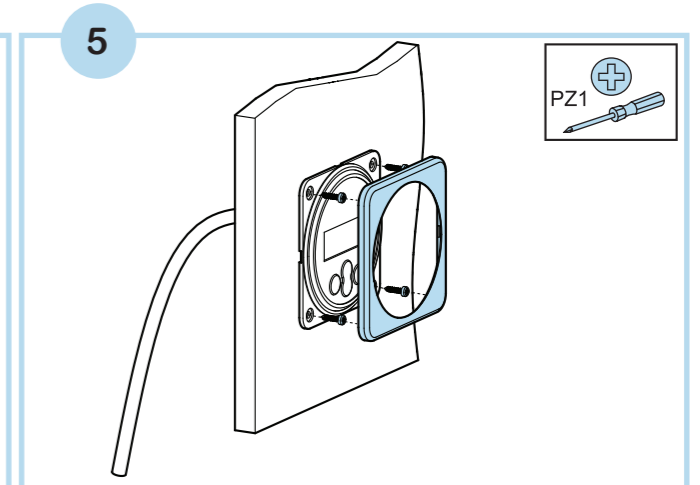
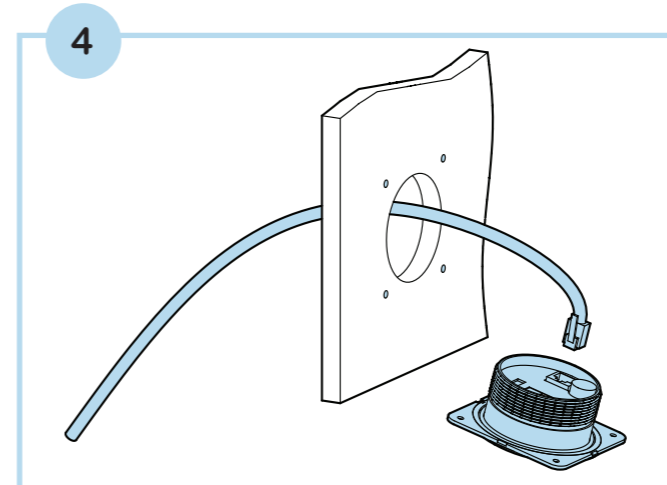
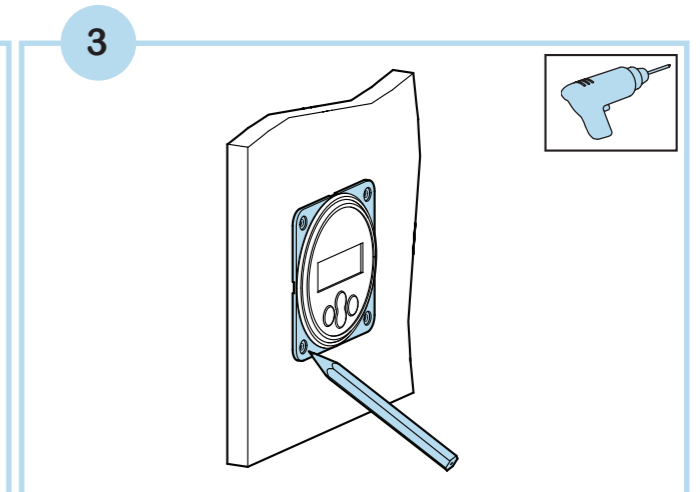
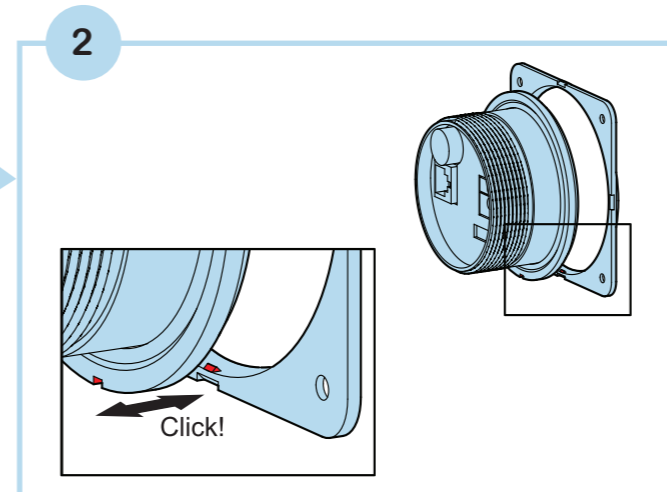
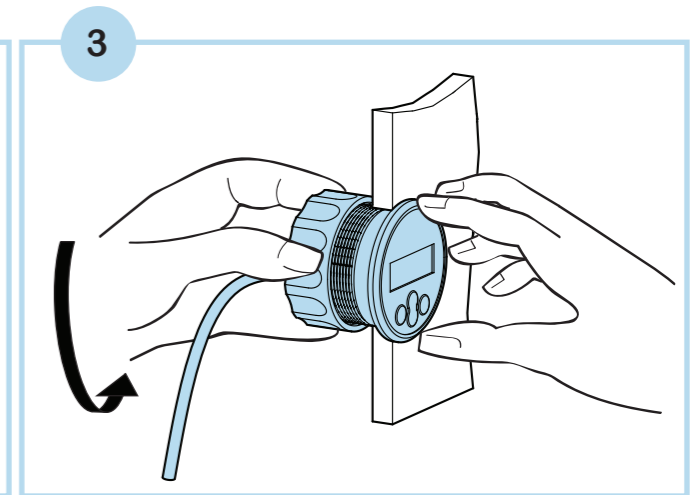
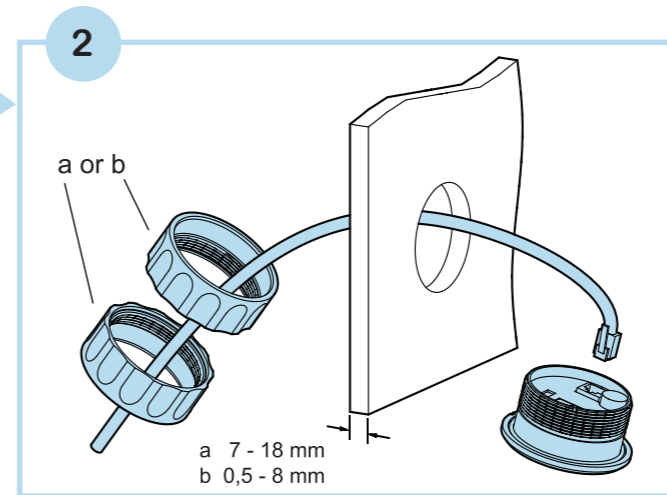
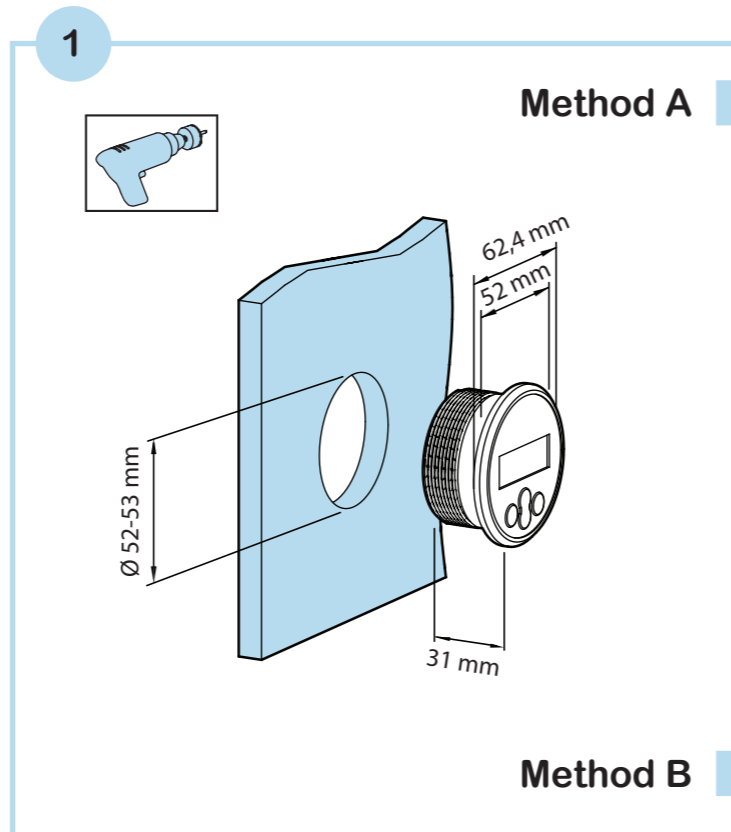

FIRST TIMERS



In case of **Li-Ion batteries**, several settings may have to be changed after the setup wizard is completed. Please refer to the manual.

The BMV will automatically adjust itself to the **nominal voltage** of **commonly** used battery systems. Please refer to the manual.

WARNING



Please read this guide carefully to avoid incorrect connections that can cause the battery monitor to malfunction and/or create a fire hazard.

Disconnect the negative pole of the battery before installation.



quick installation guide



Connect the negative pole of the battery last!

Battery monitor

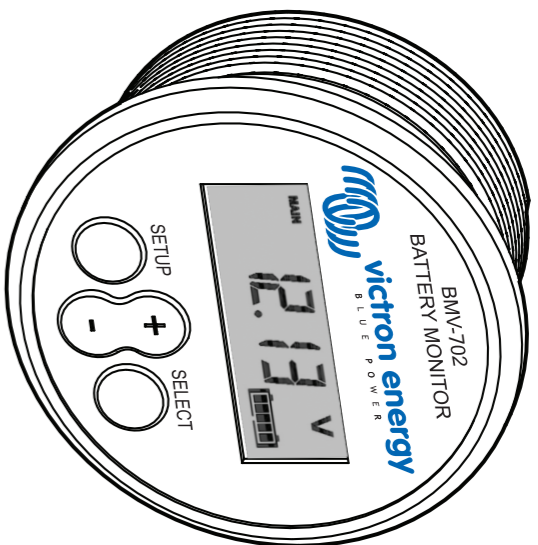

Fig. 1

Shunt

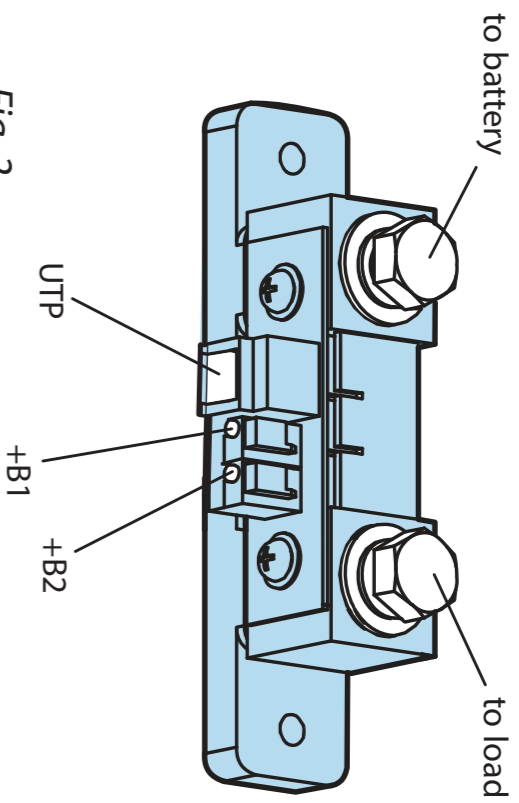

Fig. 2

Wiring diagrams



Connect the negative pole of the battery last!

BMW-700

BMW-702 configured for STARTER/AUXILIARY-battery monitoring.

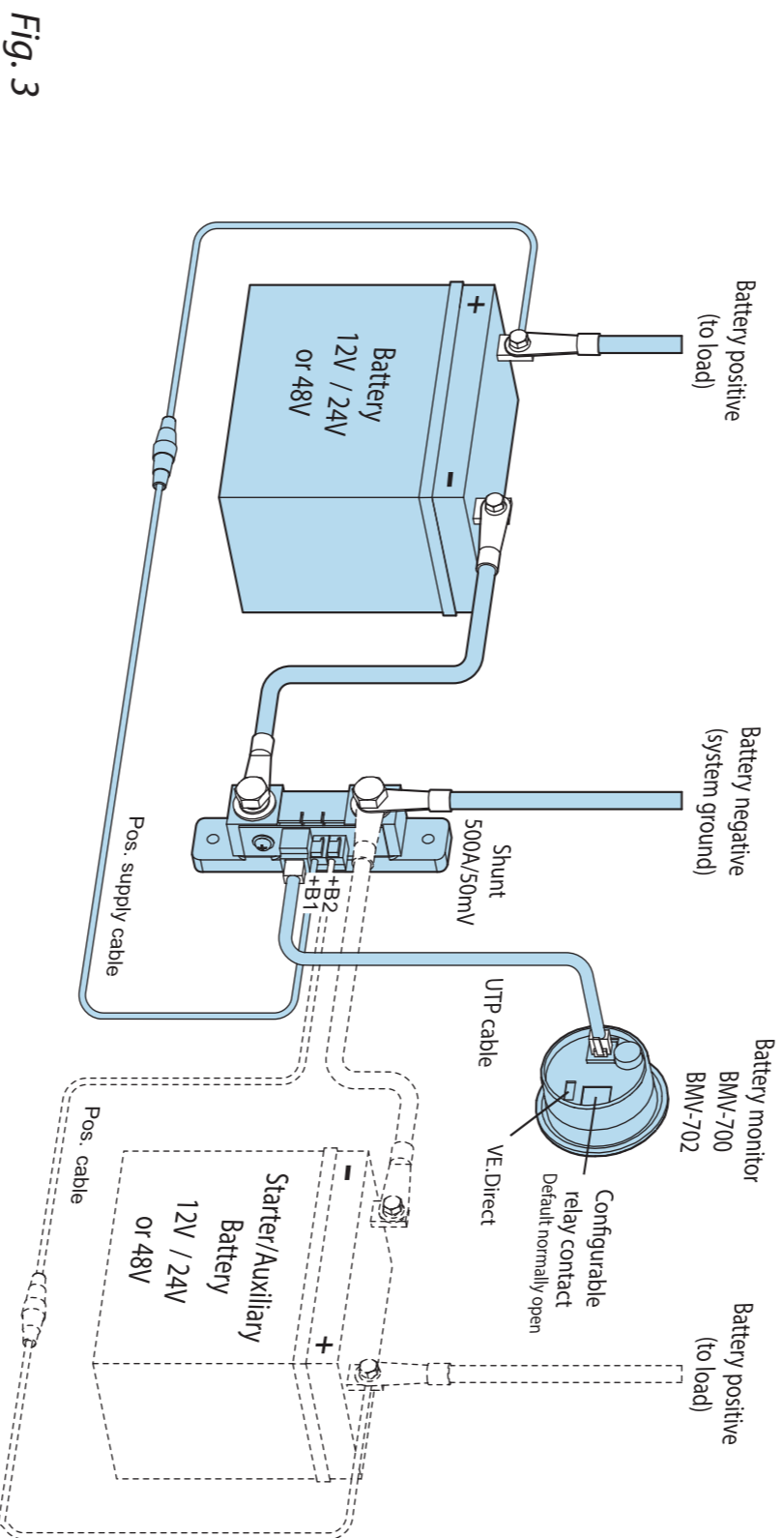

Fig. 3

BMW-702 configured for battery TEMPERATURE monitoring

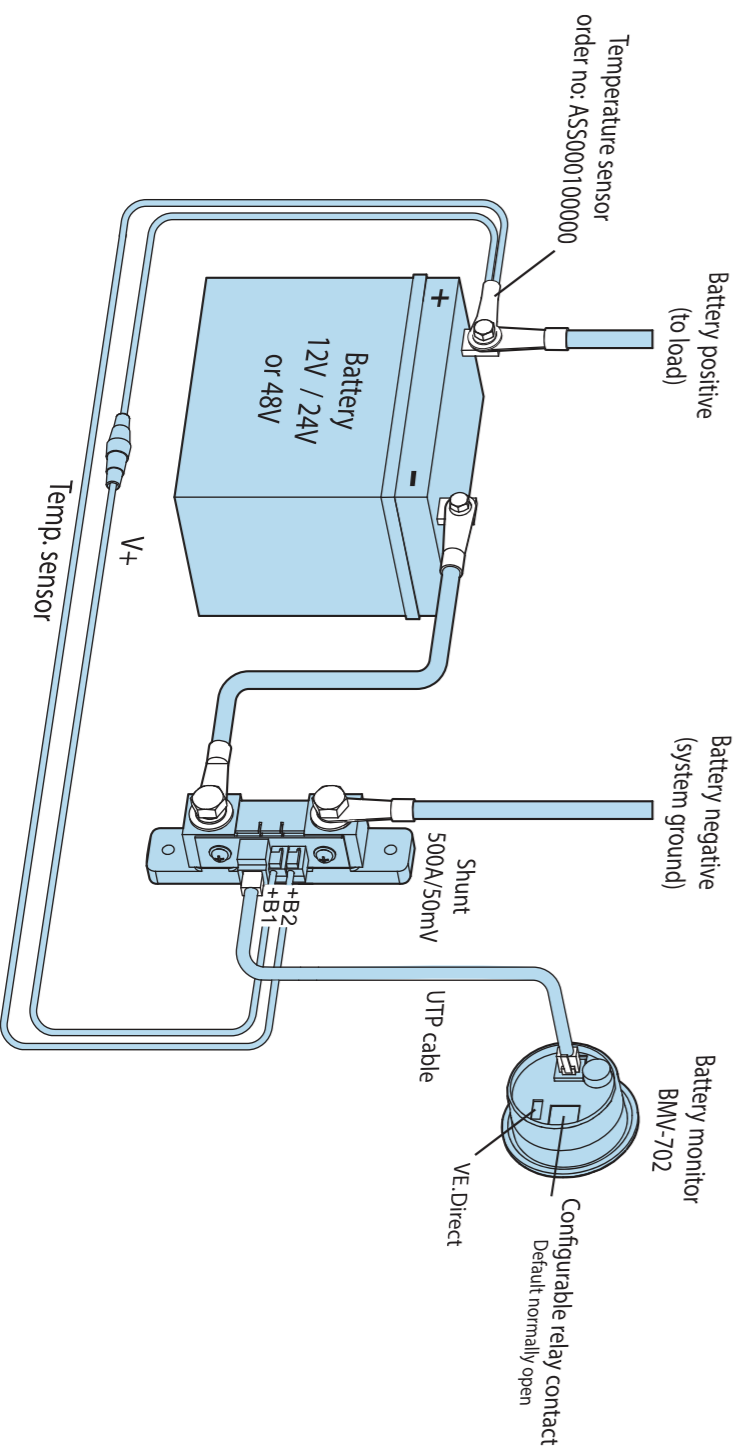

Fig. 4

Connecting multiple batteries *without* midpoint voltage monitoring : 24 V

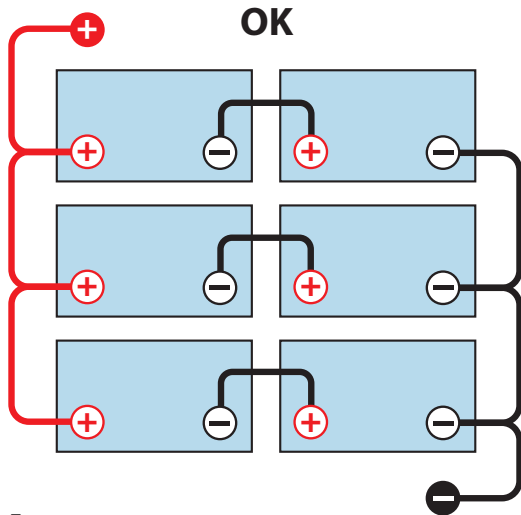

Fig. 5

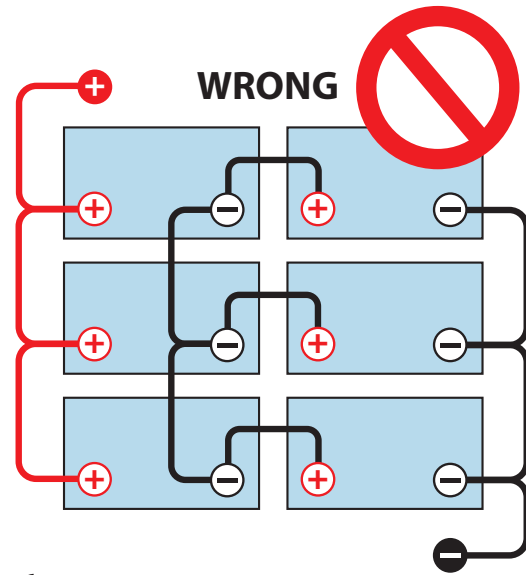

Fig. 6

Due to voltage drop over the + and - cables midpoint voltages are not identical

Applying midpoint voltage monitoring : 24 V



Always use busbars when applying midpoint voltage monitoring!
Cables to busbars must all have the same length!

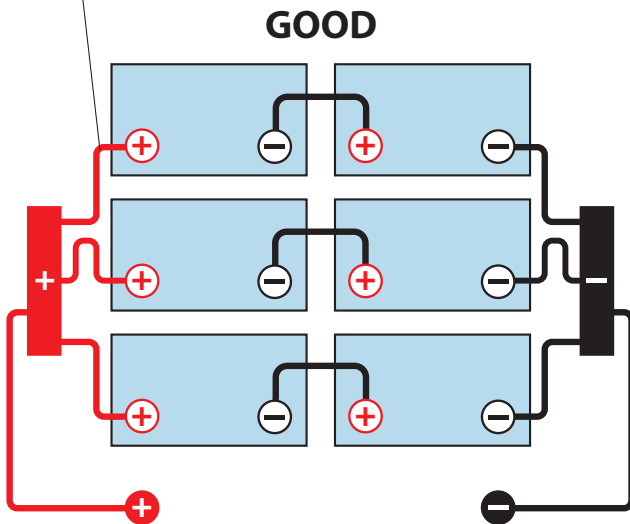

Fig. 7

Midpoints should not be interconnected: one bad battery can go unnoticed and could damage all other batteries

This cable should be short. Voltage drop over this cable will distort the midpoint measurement.

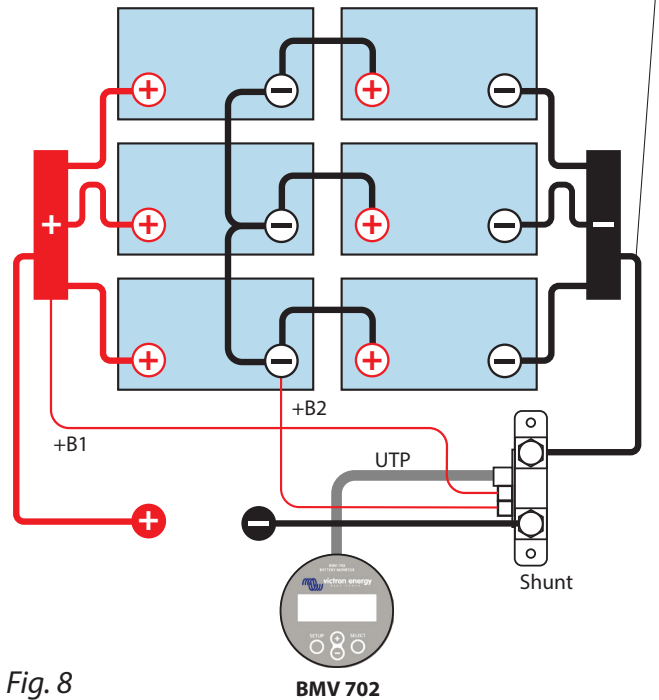

Fig. 8

Midpoints can be interconnected if corrective action is taken in case of an alarm.

In case of one string of 2 batteries +B1 and +B2 can be connected directly to the battery posts.

Connecting multiple batteries *without* midpoint voltage monitoring : 48 V

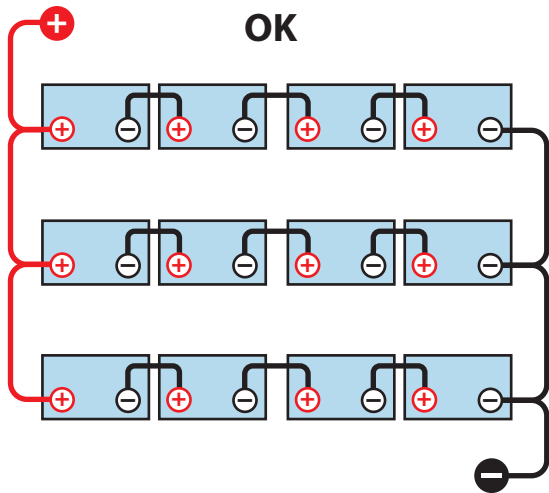

Fig. 9

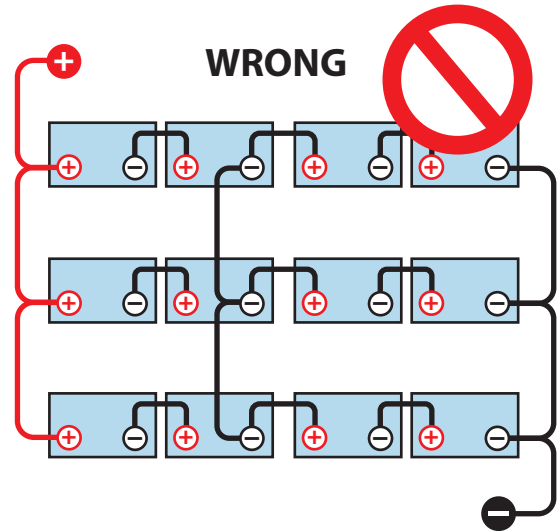

Fig. 10

Due to voltage drop over the + and - cables midpoint voltages are not identical

Applying midpoint voltage monitoring : 48 V



Always use busbars when applying midpoint voltage monitoring!
Cables to busbars must all have the same length!

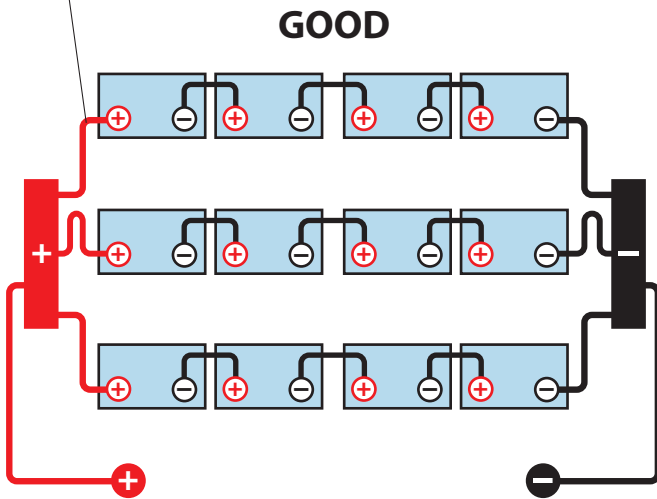

Fig. 11

Midpoints should not be interconnected: one bad battery can go unnoticed and could damage all other batteries

This cable should be short. Voltage drop over this cable will distort the midpoint measurement.

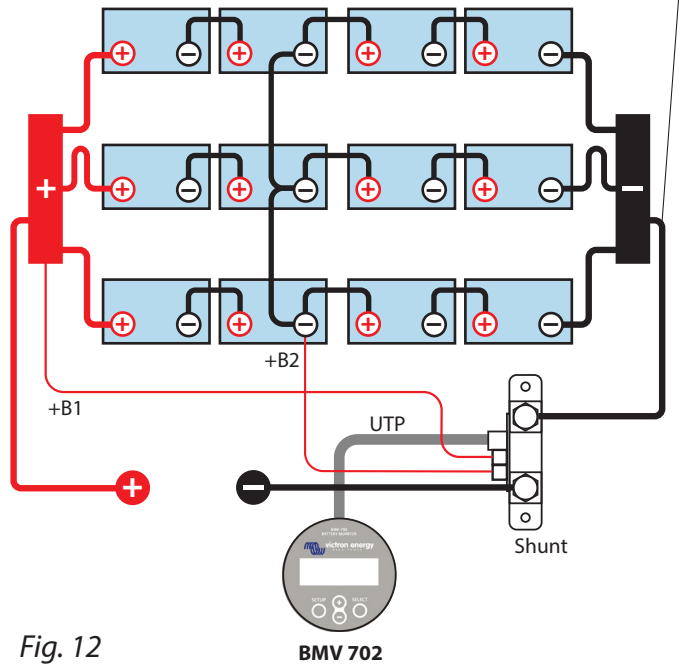

Fig. 12

Midpoints can be interconnected if corrective action is taken in case of an alarm.

In case of one string of 4 batteries +B1 and +B2 can be connected directly to the battery posts.